

CONIC SYSTEMS

Lifetime Series™

Harmonic Gearing Servo Gearheads



- Lifetime Zero Backlash
- Lifetime Ultra-High Repeatability
- Lifetime High Performance
- Lifetime High Accuracy

Lifetime Series[™] Zero Backlash Gearheads

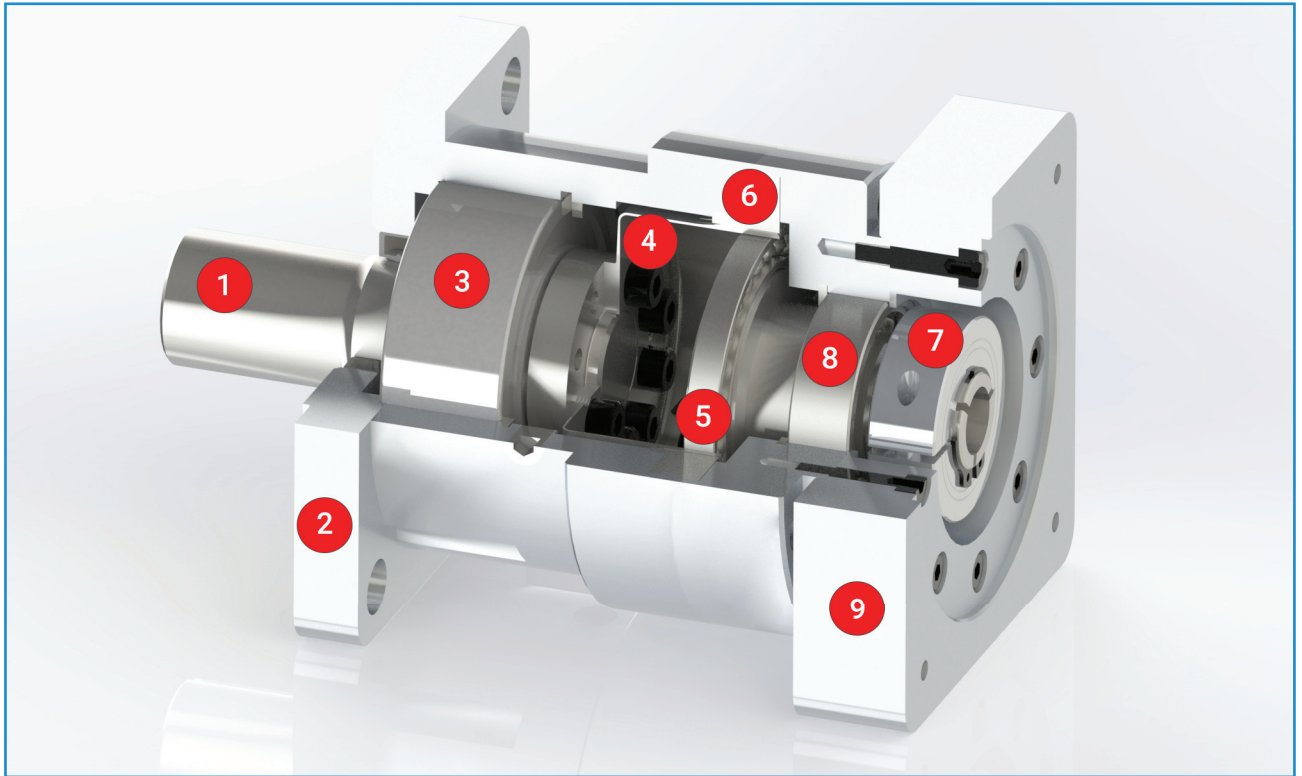

- 1 **Stressproof® Output Shaft** - provides a minimum 115,000 psi tensile strength, resistance to fatigue and excellent wearability
- 2 **Output Flange** - has a precision pilot and is available in metric, NEMA 17, 23, 34 & 42 sizes and can be factory modified to customer specifications
- 3 **Double Row Angular Contact Bearing** - provides a precision output with high stiffness, high radial and axial load capacities
- 4 **Flexspline** - a thin walled external spline that progressively engages with the Circular Spline with a zero backlash tooth mesh
- 5 **Wave Generator** - precision elliptical ball bearing that turns with the input motor and causes the rotating elliptical wave form on the Flexspline
- 6 **Circular Spline** - precision shaped internal spline, remains stationary and engages the Flexspline
- 7 **Quick Connection Motor Coupling** - a socket head tightened clamping collar provides a reliable and simple motor connection
- 8 **Sealed Bearing** - a precision bearing axially fixes the input shaft and wave generator positions
- 9 **Input Flange** - factory machined to match your motor dimensions and available in standard NEMA 17, 23, 34 & 42 sizes

Harmonic Gearing Features and Benefits

- Lifetime zero backlash
- Lifetime ultra-high repeatability (*typically a few arc-sec*)
- Lifetime high positional accuracy (± 1.5 arc-min *std.*) (± 0.5 arc-min *by request*)
- Single stage, high reduction ratios of 50:1 to 160:1
- Low noise and heat generation
- High efficiency, torsional stiffness and torque-to-weight ratio
- High torque capacity with a large number of teeth sharing load

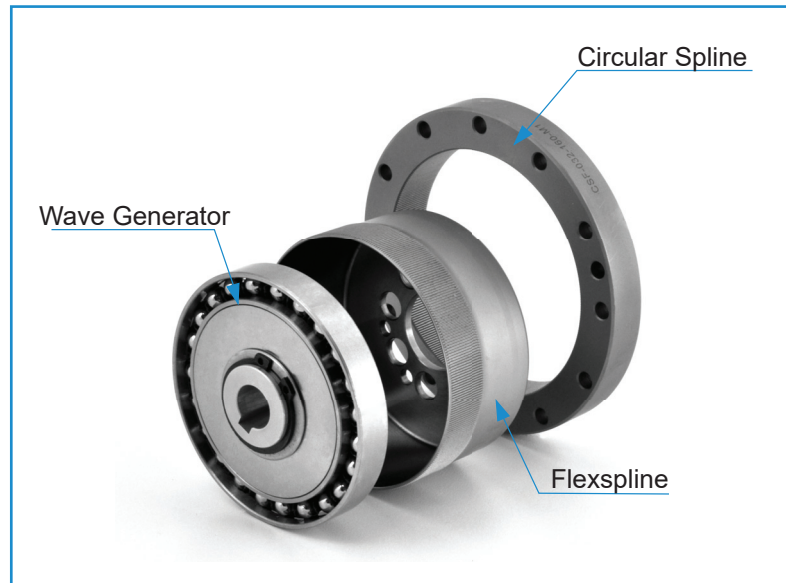

Harmonic Gearing Tooth Engagement

Tooth engagement between the Flexspline and the Circular Spline takes place at two areas located 180° to each other on the ellipse's major axis. The rotation of the wave generator inside the Flexspline generates relative motion between the two splines.

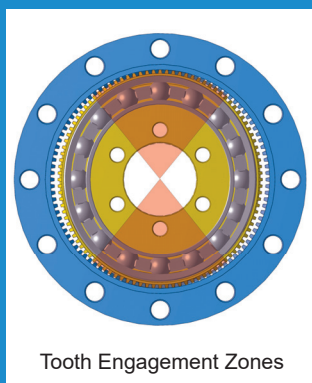
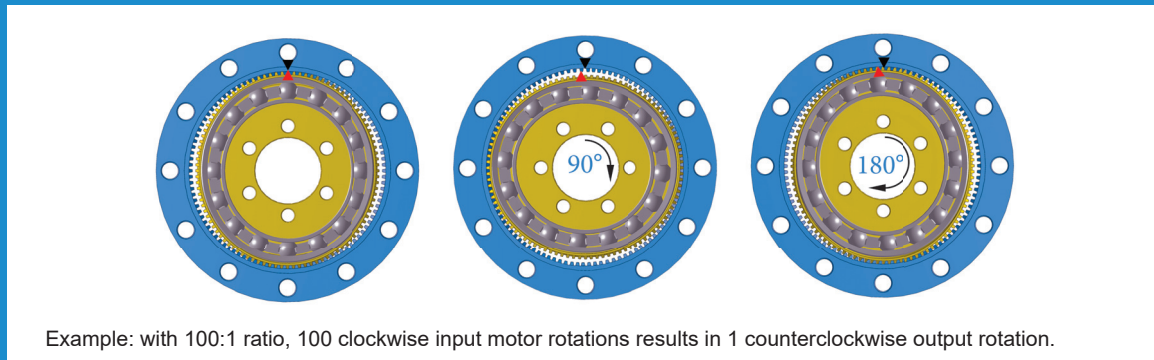

Characteristically, 30-40 percent of the teeth are engaged dependent upon the ratio, and load is shared amongst many teeth giving the drive its high torque capacity.

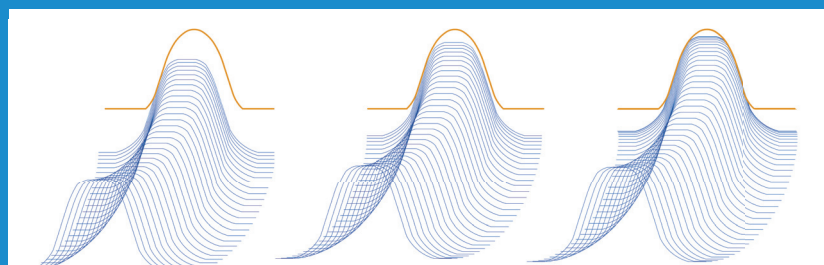

LT1 Dimensions

LT1 Gearhead (NEMA Mount: 17)

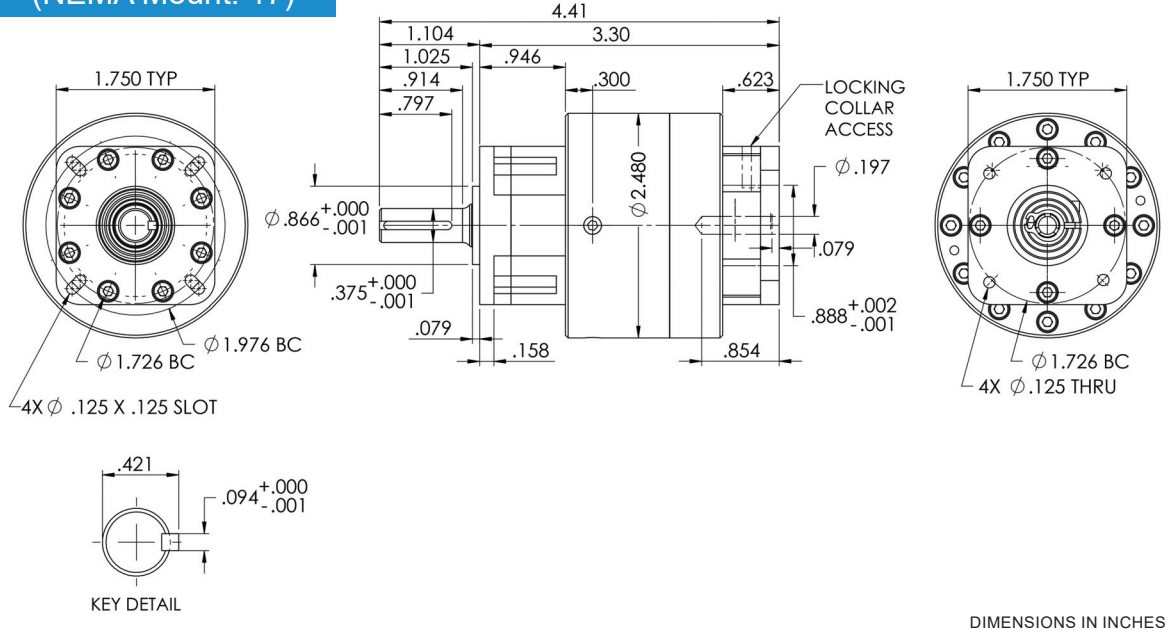

LT1 Gearhead (Metric Standard)

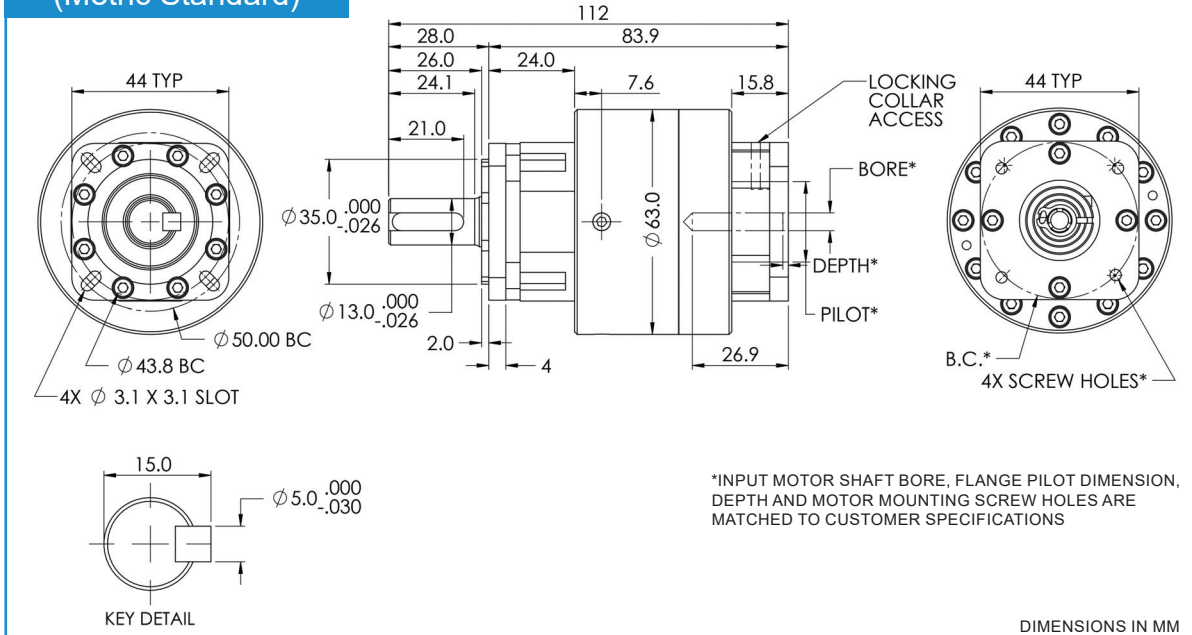

LT1 Specifications

Ratio		50	80	100
Nominal Output Torque ¹	Nm	12	12	15
Maximum Output Torque ²	Nm	24	24	30
Nominal Input Speed ³	rpm	3000		
Maximum Input Speed ⁴	rpm	7300		
Max. Radial Load ⁵	N	1268		
Max. Axial Load ⁶	N	870		
No-Load Starting Torque ⁷	Ncm	5.4	3.3	3.0
No-Load Back Driving Torque ⁸	Nm	2.3	2.6	2.7
Service Life ⁹	hrs	25000		
Torsional Rigidity ¹⁰	Nm/arc-min	2.6		
Repeatability	arc-sec	±10		
Positional Accuracy	arc-sec	±90		
Backlash	arc-sec	0		
Moment of Inertia	kgcm ²	.047		
Noise Level	dB(A)	< 67		
Protection Class	-	IP64		
Permitted Housing Temp	°C	90		
Permitted Ambient Temp	°C	0 - 40		
Lubrication ¹¹	-	Permanent		
Weight ¹²	kg	.68		

- 1) Rated torque at 3,000 rpm input for an average life of 25,000 hours
- 2) Exceeding the maximum output torque limit may immediately damage the drive
- 3) Input speed at rated output torque for an average life of 25,000 hours
- 4) The maximum intermittent input speed
- 5) At key center line of output shaft, calculated at 100 rpm output speed and nominal output torque
- 6) At end of output shaft, calculated at 100 rpm output speed and nominal output torque
- 7) Minimum input torque required to turn the output shaft with no load
- 8) Minimum torque, if applied to the output shaft, that will cause the unit to back drive
- 9) Average life at nominal load and input speed
- 10) Torsional rigidity at nominal torque
- 11) Mobil Beacon 325 grease, synthetic oil available on request
- 12) Weight may vary slightly dependent upon adapter options

LT2 Dimensions

LT2 Gearhead (NEMA Mount: 23)

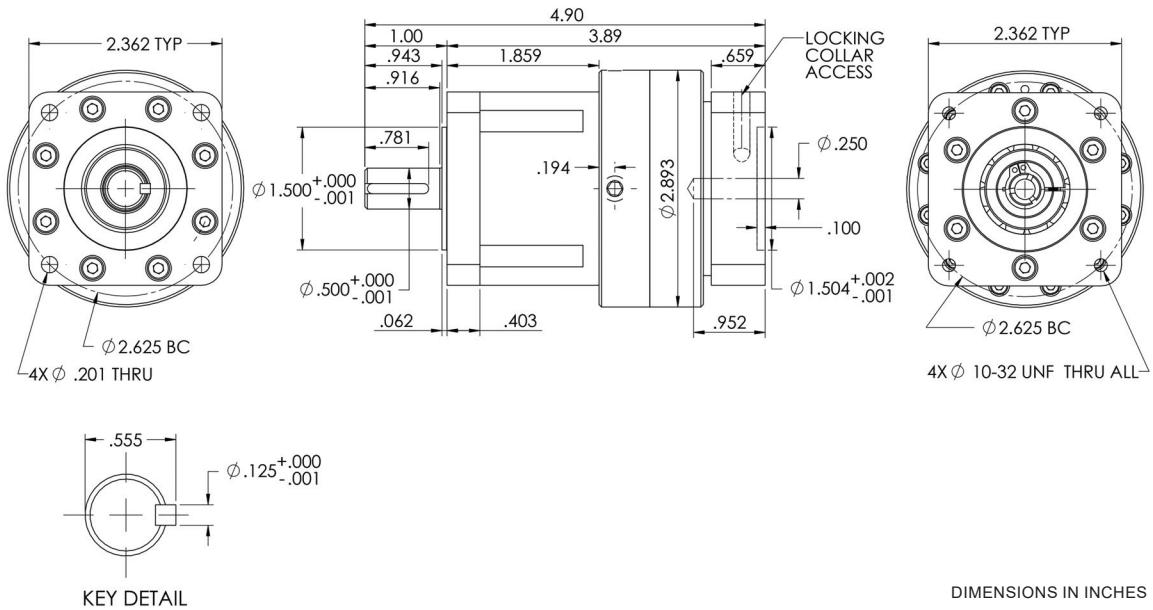

LT2 Gearhead (Metric Standard)

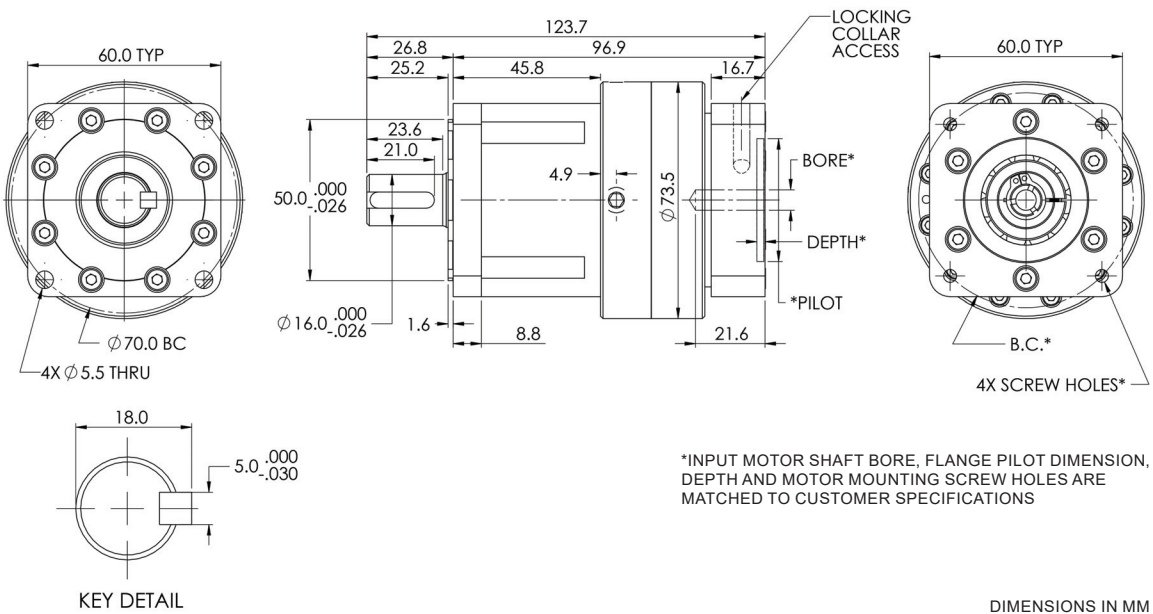

LT2 Specifications

Ratio		50	80	100	120	160
Nominal Output Torque ¹	Nm	25	25	30	30	30
Maximum Output Torque ²	Nm	50	50	60	60	60
Nominal Input Speed ³	rpm	3000				
Maximum Input Speed ⁴	rpm	6500				
Max. Radial Load ⁵	N	2376				
Max. Axial Load ⁶	N	1557				
No-Load Starting Torque ⁷	Ncm	6.2	4.6	4.3	3.3	2.3
No-Load Back Driving Torque ⁸	Nm	4	4.2	4.5	6.6	7
Service Life ⁹	hrs	25000				
Torsional Rigidity ¹⁰	Nm/arc-min	4.5				
Repeatability	arc-sec	±10				
Positional Accuracy	arc-sec	±90				
Backlash	arc-sec	0				
Moment of Inertia	kgcm ²	.161				
Noise Level	dB(A)	< 67				
Protection Class	-	IP64				
Permitted Housing Temp.	°C	90				
Permitted Ambient Temp.	°C	0 - 40				
Lubrication ¹¹	-	Permanent				
Weight ¹²	kg	1.2				

- 1) Rated torque at 3,000 rpm input for an average life of 25,000 hours
- 2) Exceeding the maximum output torque limit may immediately damage the drive
- 3) Input speed at rated output torque for an average life of 25,000 hours
- 4) The maximum intermittent input speed
- 5) At key center line of output shaft, calculated at 100 rpm output speed and nominal output torque
- 6) At end of output shaft, calculated at 100 rpm output speed and nominal output torque
- 7) Minimum input torque required to turn the output shaft with no load
- 8) Minimum torque, if applied to the output shaft, that will cause the unit to back drive
- 9) Average life at nominal load and input speed
- 10) Torsional rigidity at nominal torque
- 11) Mobil Beacon 325 grease, synthetic oil available on request
- 12) Weight may vary slightly dependent upon adapter options

LT3 Dimensions

LT3 Gearhead (NEMA Mount: 34)

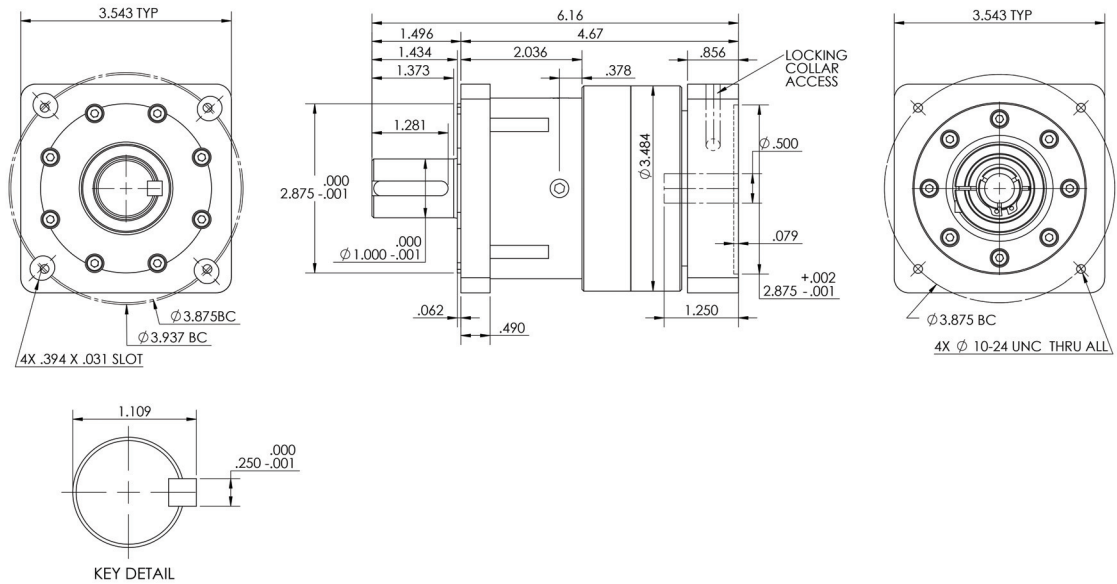

DIMENSIONS IN INCHES

LT3 Gearhead (Metric Standard)

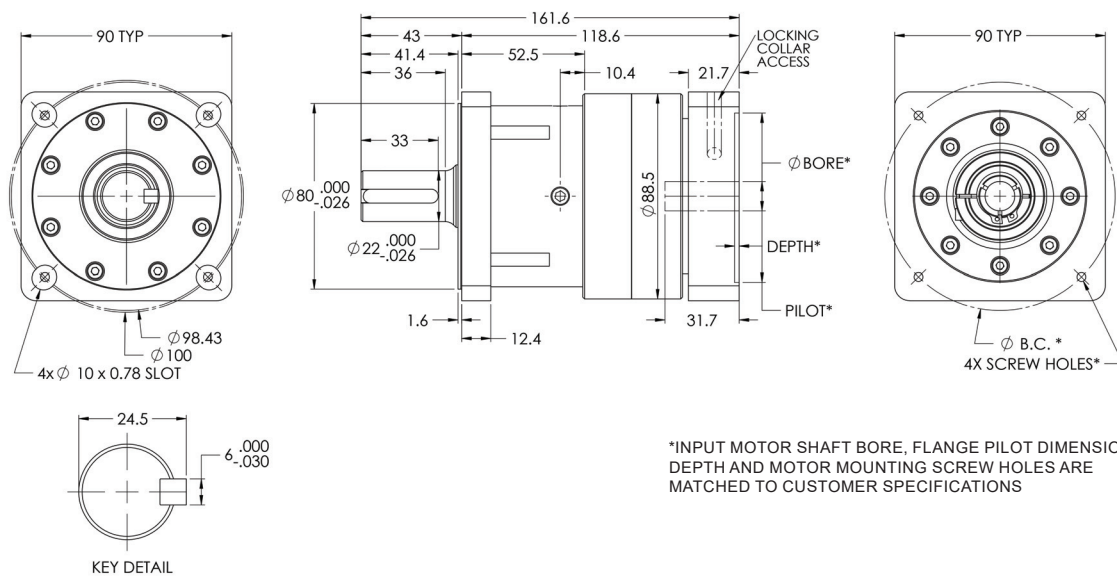

*INPUT MOTOR SHAFT BORE, FLANGE PILOT DIMENSION, DEPTH AND MOTOR MOUNTING SCREW HOLES ARE MATCHED TO CUSTOMER SPECIFICATIONS

DIMENSIONS IN MM

LT3 Specifications

Ratio		50	80	100	120	160
Nominal Output Torque ¹	Nm	40	40	50	50	50
Maximum Output Torque ²	Nm	80	80	100	100	100
Nominal Input Speed ³	rpm	3000				
Maximum Input Speed ⁴	rpm	5600				
Max. Radial Load ⁵	N	2230				
Max. Axial Load ⁶	N	3717				
No-Load Starting Torque ⁷	Ncm	14	7	7	6	6
No-Load Back Driving Torque ⁸	Nm	7	7.2	8.5	9	11.3
Service Life ⁹	hrs	25000				
Torsional Rigidity ¹⁰	Nm/arc-min	24				
Repeatability	arc-sec	±10				
Positional Accuracy	arc-sec	±90				
Backlash	arc-sec	0				
Moment of Inertia	kgcm ²	.506				
Noise Level	dB(A)	< 67				
Protection Class	-	IP64				
Permitted Housing Temp	°C	90				
Permitted Ambient Temp	°C	0 - 40				
Lubrication ¹¹	-	Permanent				
Weight ¹²	kg	2.6				

- 1) Rated torque at 3,000 rpm input for an average life of 25,000 hours
- 2) Exceeding the maximum output torque limit may immediately damage the drive
- 3) Input speed at rated output torque for an average life of 25,000 hours
- 4) The maximum intermittent input speed.
- 5) At key center line of output shaft, calculated at 100 rpm output speed and nominal output torque
- 6) At end of output shaft, calculated at 100 rpm output speed and nominal output torque
- 7) Minimum input torque required to turn the output shaft with no load
- 8) Minimum torque, if applied to the output shaft, that will cause the unit to back drive
- 9) Average life at nominal load and input speed
- 10) Torsional rigidity at nominal torque
- 11) Mobil Beacon 325 grease, synthetic oil available on request
- 12) Weight may vary slightly dependent upon adapter options

LT4 Dimensions

LT4 Gearhead (NEMA Mount: 42)

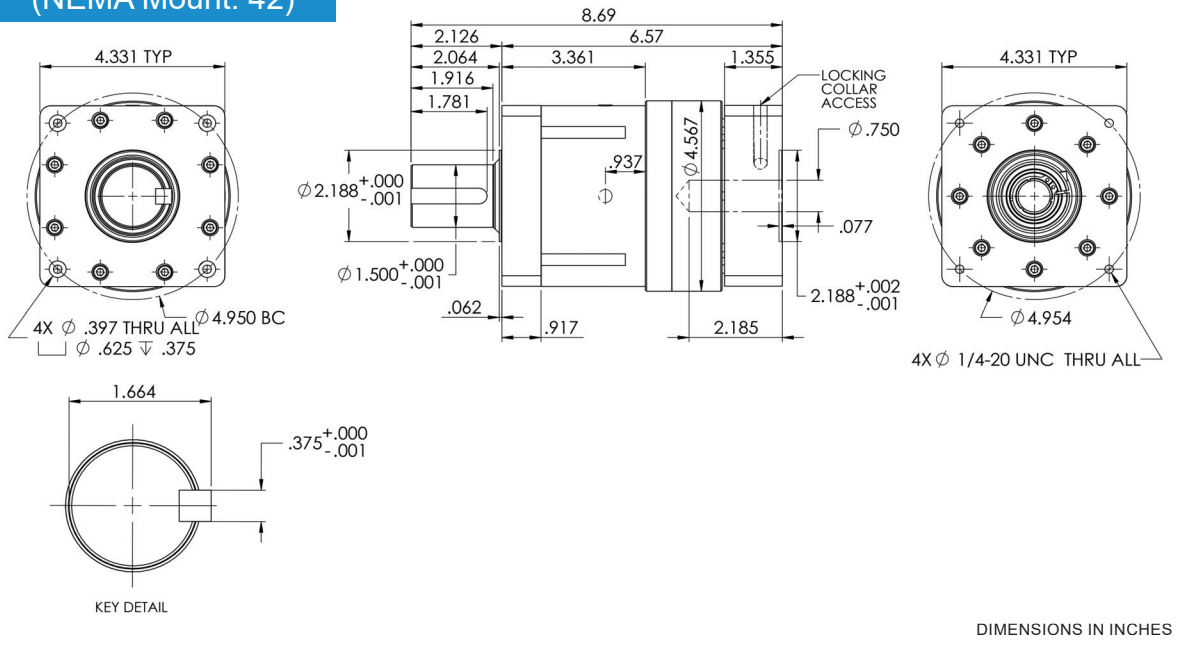

LT4 Gearhead (Metric Standard)

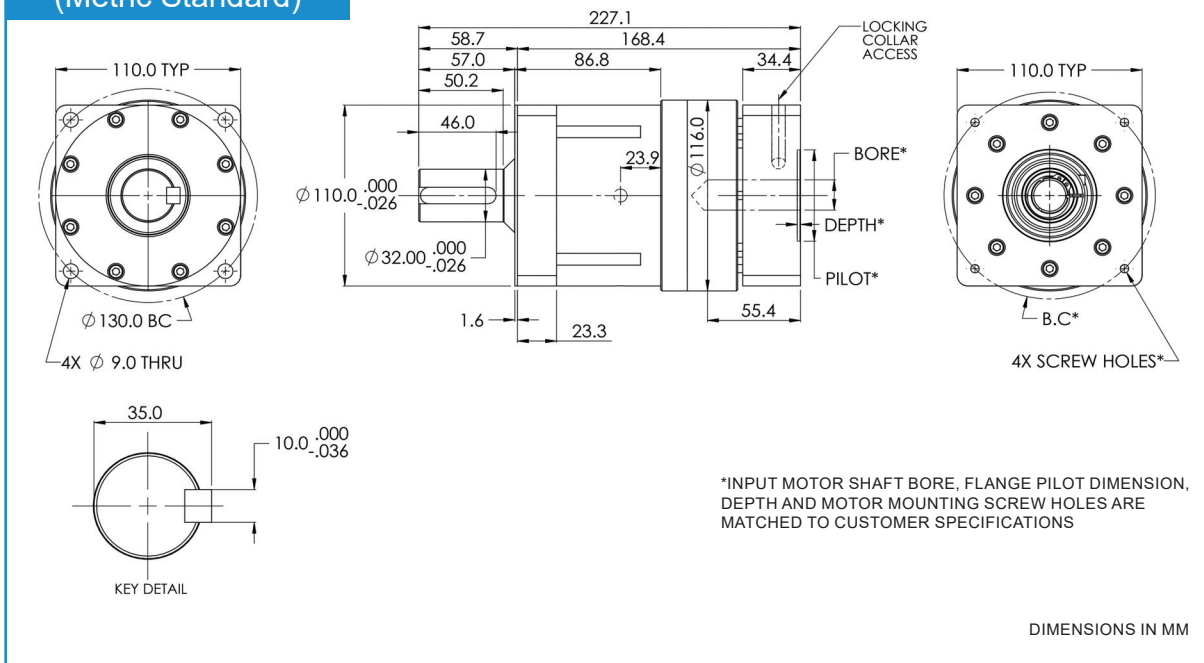

LT4 Specifications

Ratio		50	80	100	135	160	200
Nominal Output Torque ¹	Nm	100	100	120	120	120	120
Maximum Output Torque ²	Nm	200	200	240	240	240	240
Nominal Input Speed ³	rpm	3000					
Maximum Input Speed ⁴	rpm	4800					
Max. Radial Load ⁵	N	6012					
Max. Axial Load ⁶	N	3985					
No-Load Starting Torque ⁷	Ncm	38	18	16	14	12	11
No-Load Back Driving Torque ⁸	Nm	11	14	15	20	21	22
Service Life ⁹	hrs	25000					
Torsional Rigidity ¹⁰	Nm/arc-min	32					
Repeatability	arc-sec	±10					
Positional Accuracy	arc-sec	±90					
Backlash	arc-sec	0					
Moment of Inertia	kgcm ²	2.12					
Noise Level	dB(A)	< 67					
Protection Class	-	IP64					
Permitted Housing Temp	°C	90					
Permitted Ambient Temp	°C	0 - 40					
Lubrication ¹¹	-	Permanent					
Weight ¹²	kg	6.3					

- 1) Rated torque at 3,000 rpm input for an average life of 25,000 hours
- 2) Exceeding the maximum output torque limit may immediately damage the drive
- 3) Input speed at rated output torque for an average life of 25,000 hours
- 4) The maximum intermittent input speed
- 5) At key center line of output shaft, calculated at 100 rpm output speed and nominal output torque
- 6) At end of output shaft, calculated at 100 rpm output speed and nominal output torque
- 7) Minimum input torque required to turn the output shaft with no load
- 8) Minimum torque, if applied to the output shaft, that will cause the unit to back drive
- 9) Average life at nominal load and input speed
- 10) Torsional rigidity at nominal torque
- 11) Mobil Beacon 325 grease, synthetic oil available on request
- 12) Weight may vary slightly dependent upon adapter options

Selection Guide

Step 1: Determine Your Application Motion Profile and Loading

Proper sizing and selection of the Conic servo gearheads includes review of the harmonic gear service life and confirmation that output bearing load ratings are not exceeded. The harmonic gear life is based upon input motor speed and output torque requirements. The output bearing load check requires review of the axial and radial loads applied to the output shaft and average output speed.

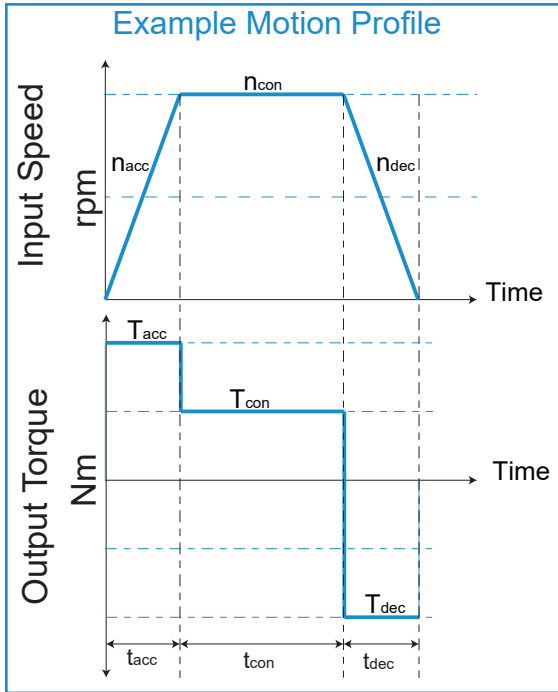

Review and note the following application data points for use in selecting the proper gearhead.

- n_{acc} = average input speed during accel (rpm)
- n_{con} = input speed during operation (rpm)
- n_{dec} = average input speed during decel (rpm)
- T_{acc} = acceleration torque (Nm)
- T_{con} = constant torque (Nm)
- T_{dec} = deceleration torque (Nm)
- t_{acc} = acceleration time (sec)
- t_{con} = constant run time (sec)
- t_{dec} = deceleration time (sec)
- F_r = radial load applied at output shaft (N)
- F_a = axial load applied at output shaft (N)
- L_{hr} = required gearhead service life (hrs)

Step 2: Calculate Average Output Torque and Input Speed

Calculate the average output torque and average input speed based upon your motion profile.

Average Output Torque

$$T_{avg} = \sqrt[3]{\frac{n_{acc} * t_{acc} * |T_{acc}^3| + n_{con} * t_{con} * |T_{con}^3| + n_{dec} * t_{dec} * |T_{dec}^3|}{n_{acc} * t_{acc} + n_{con} * t_{con} + n_{dec} * t_{dec}}}$$

Average Input Speed

$$n_{i(avg)} = \frac{n_{acc} * t_{acc} + n_{con} * t_{con} + n_{dec} * t_{dec}}{t_{acc} + t_{con} + t_{dec}}$$

Step 3: Select Gearhead Size and Ratio

Compare your calculated average output torque (T_{avg}) against the nominal output torque rating in the gearhead specification tables. Conic Systems recommends selecting a gearhead with a nominal output torque higher than the application's average torque for the greatest service life. The nominal rated torque can be exceeded by up to 50%, but service life will be reduced. Ensure the maximum output torque and maximum input speeds are not exceeded, or immediate damage may occur. If the desired service life exceeds 25,000 hours, calculate the anticipated service life based upon the method provided in Step 4.

Step 4: Calculate Service Life

Conic Systems harmonic gearing servo gearheads are rated for 25,000 hours of operation at nominal output torque and nominal input speed. Based upon your calculated average torque and average input speed, the estimated service life can be calculated using the equation below. If the calculated Service Life (Lhr) is lower than is desired, a larger size should be selected. If the Lhr is higher than required, a smaller size may meet your requirements. Contact Conic Systems engineering department for further information and assistance if required.

$$L_{hr} = 25000 * \left(\frac{T_{nom}}{T_{avg}} \right)^3 * \frac{n_{nom}}{n_{i(avg)}}$$

T_{nom} = Nominal Output Torque

T_{avg} = Average Output Torque

n_{nom} = Nominal Input Speed

$n_{i(avg)}$ = Average Input Speed

Step 5: Determine Average Radial and Axial Loads

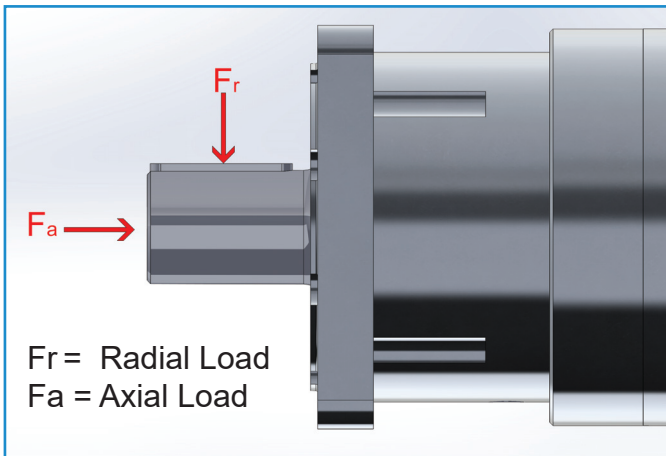

Radial and axial load maximums are listed under specifications by frame size. Radial load maximums are calculated with the load applied at key center. The average radial and axial forces can be calculated using the equations provided below. If the forces calculated exceed maximums for the gearhead, select a larger size or contact Conic Systems for further assistance.

Fr_{avg} = average radial force applied at the midpoint of the shaft

Fa_{avg} = average axial force applied along the center of the shaft

$$Fr_{avg} = \sqrt[3]{\frac{n_{acc} * t_{acc} * |Fr_{acc}|^3 + n_{con} * t_{con} * |Fr_{con}|^3 + n_{dec} * t_{dec} * |Fr_{dec}|^3}{n_{acc} * t_{acc} + n_{con} * t_{con} + n_{dec} * t_{dec}}}$$

$$Fa_{avg} = \sqrt[3]{\frac{n_{acc} * t_{acc} * |Fa_{acc}|^3 + n_{con} * t_{con} * |Fa_{con}|^3 + n_{dec} * t_{dec} * |Fa_{dec}|^3}{n_{acc} * t_{acc} + n_{con} * t_{con} + n_{dec} * t_{dec}}}$$

Selection Example

Step 1:

Assume a selection for a 100:1 ratio gearhead with a timing belt drive on the output shaft.

Operation Cycle:

Starting (acceleration): $T_{acc} = 75 \text{ Nm}$, $t_{acc} = 0.4 \text{ sec}$, $n_{acc} = 1100 \text{ rpm}$, $Fr = 5580 \text{ N}$, $Fa = 0 \text{ N}$

Steady State (constant): $T_{con} = 60 \text{ Nm}$, $t_{con} = 8.0 \text{ sec}$, $n_{con} = 2200 \text{ rpm}$, $Fr = 4462 \text{ N}$, $Fa = 0 \text{ N}$

Stopping (deceleration): $T_{dec} = 75 \text{ Nm}$, $t_{dec} = 0.4 \text{ sec}$, $n_{dec} = 1100 \text{ rpm}$, $Fr = 5580 \text{ N}$, $Fa = 0 \text{ N}$

Step 2:

Calculate the average output torque and average input rotational speed.

$$T_{avg} = \sqrt[3]{\frac{1100 \text{ rpm} * 0.4 \text{ sec} * |75 \text{ Nm}|^3 + 2200 \text{ rpm} * 8 \text{ sec} * |60 \text{ Nm}|^3 + 1100 \text{ rpm} * 0.4 \text{ sec} * |75 \text{ Nm}|^3}{1100 \text{ rpm} * 0.4 \text{ sec} + 2200 \text{ rpm} * 8 \text{ sec} + 1100 \text{ rpm} * 0.4 \text{ sec}}}$$

$$T_{avg} = 60.89 \text{ Nm}$$

$$n_{i(avg)} = \frac{1100 \text{ rpm} * 0.4 \text{ sec} + 2200 \text{ rpm} * 8 \text{ sec} + 1100 \text{ rpm} * 0.4 \text{ sec}}{0.4 \text{ sec} + 8 \text{ sec} + 0.4 \text{ sec}}$$

$$n_{i(avg)} = 2100 \text{ rpm}$$

Step 3:

A preliminary selection is made based on a calculated T_{avg} of 60.89 Nm and an $n_{i(avg)}$ of 2100 rpm. A comparison of gearhead sizes at ratio 100:1 indicates the LT4 would best meet operational needs. A life calculation should then be made to verify the gearhead suitability to application.

Step 4:

$$L_{hrs} = 25000 * \left(\frac{120 \text{ Nm}}{60.89 \text{ Nm}}\right)^3 * \frac{3000 \text{ rpm}}{2100 \text{ rpm}} = 273,368$$

After establishing that the service life estimate meets your needs, ensure the average radial and axial forces do not exceed maximums for the unit. As there are no axial forces on the output shaft in this example, only a calculation for average radial force is necessary.

Step 5:

$$Fr_{avg} = \sqrt[3]{\frac{1100 \text{ rpm} * 0.4 \text{ sec} * |5580 \text{ N}|^3 + 2200 \text{ rpm} * 8 \text{ sec} * |4462 \text{ N}|^3 + 1100 \text{ rpm} * 0.4 \text{ sec} * |5580 \text{ N}|^3}{1100 \text{ rpm} * 0.4 \text{ sec} + 2200 \text{ rpm} * 8 \text{ sec} + 1100 \text{ rpm} * 0.4 \text{ sec}}}$$

The calculated Fr_{avg} is 4528 N \leq 6012 (Max Radial Load for LT4).

Ordering Codes

LT Series

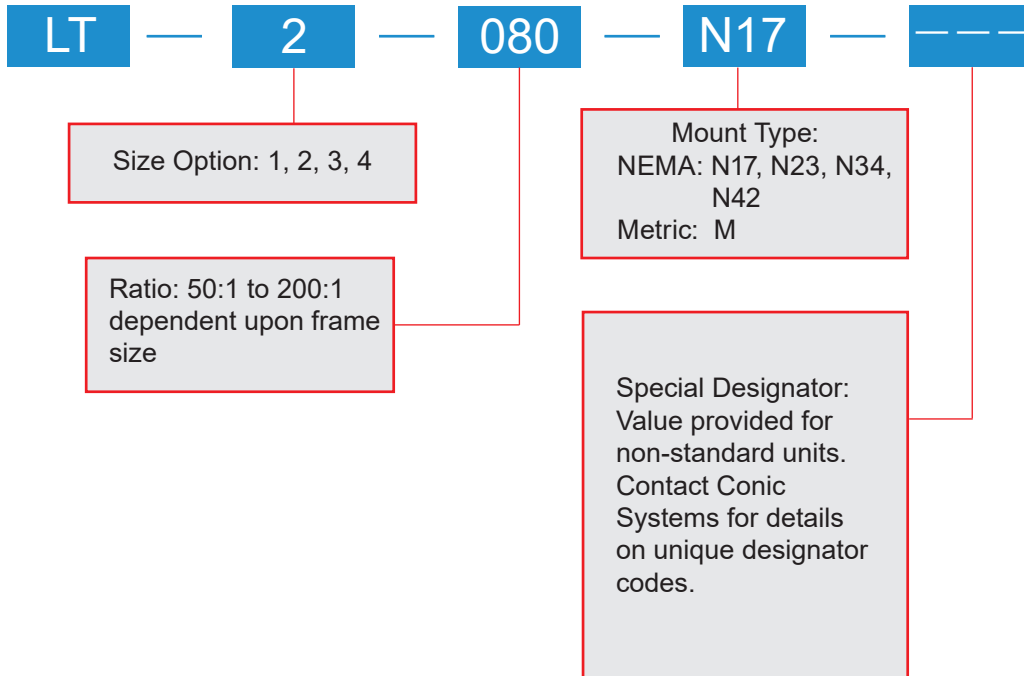

Disclaimer

Notice: All efforts have been made to assure that the information in this catalog is complete and accurate. However, Conic Systems is not liable for any errors, omissions, or inaccuracies in the reported data. Conic Systems reserves the right to change the product specifications, for any reason, without prior notice. Customers are responsible for determining product applicability to any particular application.



Harmonic Gearing for Automation

Phone: 845-856-4053 • Toll Free: 888-757-2547 • www.conicsystems.com
info@conicsystems.com • 11 Rebel Lane, Port Jervis, NY 12771